

150S Series

150W SINGLE OUTPUT

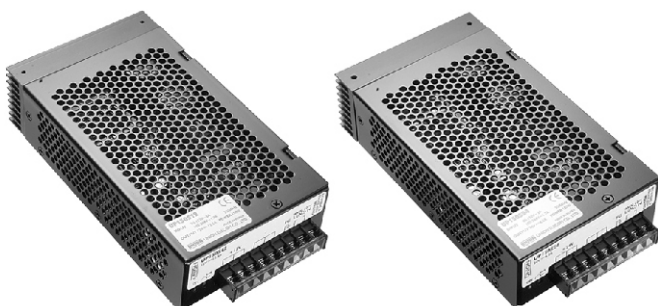

- ▶ Constant voltage design
- ▶ Dual input range (selectable by jumper-wire)
- ▶ Protection : Over load /Over voltage/Short circuit
- ▶ 100% full load burn-in test
- ▶ DC Adjust range : Fixed, can be modified within $\pm 5\%$ rated output voltage
- ▶ Suitable for LED lighting and industrial applications
- ▶ Safety standards : EN60950-1/K61347-2-1,K61347-2-13
- ▶ EMC standards : K00015,K61547,K61000-4-2,3,4,5,6,11
- ▶ 3years warranty



(For 12V,24V only)



SPECIFICATIONS

Item		UP150S05	UP150S12	UP150S15	UP150S24
INPUT	VOLTAGE	AC90~132V/180~264V			
	FREQUENCY	50/60Hz(47~63Hz)			
	EFFICIENCY	75% Typ	78% Typ	80% Typ	80% Typ
	INRUSH CURRENT	20A Typ(ACIN 110V, Io=100%)/40A Typ(ACIN 220V, Io=100%) at cold start			
OUTPUT	VOLTAGE [V]	5	12	15	24
	CURRENT [A]	30.0	12.5	10.0	6.2
	LINE REGULATION [mV]	25 Max	60 Max	75 Max	120 Max
	LOAD REGULATION [mV]	50 Max	120 Max	150 Max	240 Max
	RIPPLE [mVp-p]	50 Max	120 Max	150 Max	240 Max
	RIPPLE NOISE [mVp-p]	100 Max	170 Max	200 Max	290 Max
	TEMPERATURE DRIFT,0-50°C [mV]	50 Max	120 Max	150 Max	240 Max
	RISE TIME [msec]	100 Max(ACIN 90V, Io=100%)			
HOLDING TIME [msec]	15 Typ(ACIN 90V/180V, Io=100%)				
PROTECTION	OVER CURRENT PROTECTION	Works at over 110% of rating and recovers automatically			
	OVER VOLTAGE PROTECTION	Works at 115~140% of rating			
ISOLATION	INPUT-OUTPUT	AC3,000V for 1 minute, DC500V 100Mohm (At room temp. & humid.)			
	INPUT-CASE, FG	AC1,500V for 1 minute, DC500V 100Mohm (At room temp. & humid.)			
	OUTPUT-CASE	AC500V for 1 minute, DC500V 100Mohm (At room temp. & humid.)			
ENVIRONMENT	OPERATING TEMP. & HUMID.	-10~+60°C (refer to "DERATING CURVE"),20~90%RH			
	STORAGE TEMP. & HUMID.	-10~+75°C,20~90%RH			
	VIBRATION	10~55Hz at 1G 3 minutes period, 30 minutes along X, Y and Z axis			
	IMPACT	10G for 20 msec, Once on each X, Y and Z axis			

S.M.P.S

Enclosed Switching Power Supply

General Type

BLOCK DIAGRAM

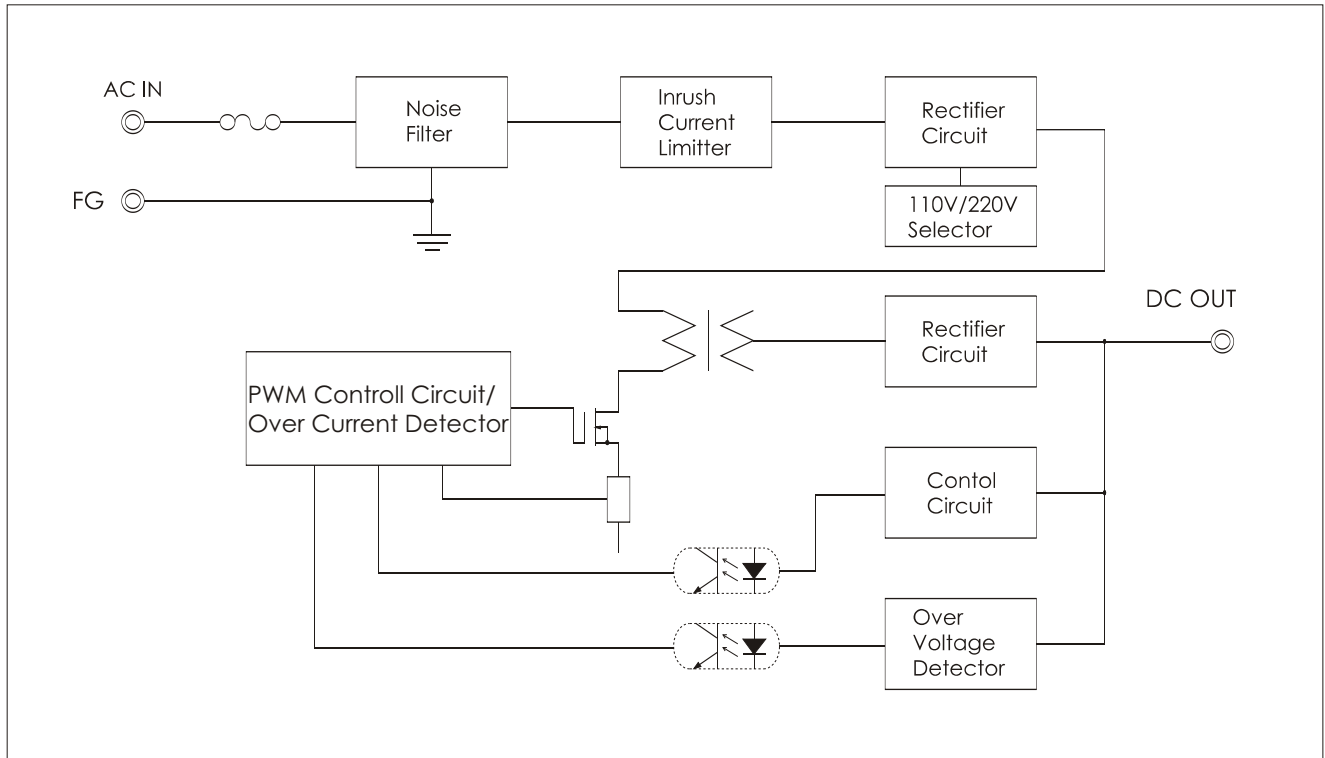

DIMENSIONS(UNITS : MM)

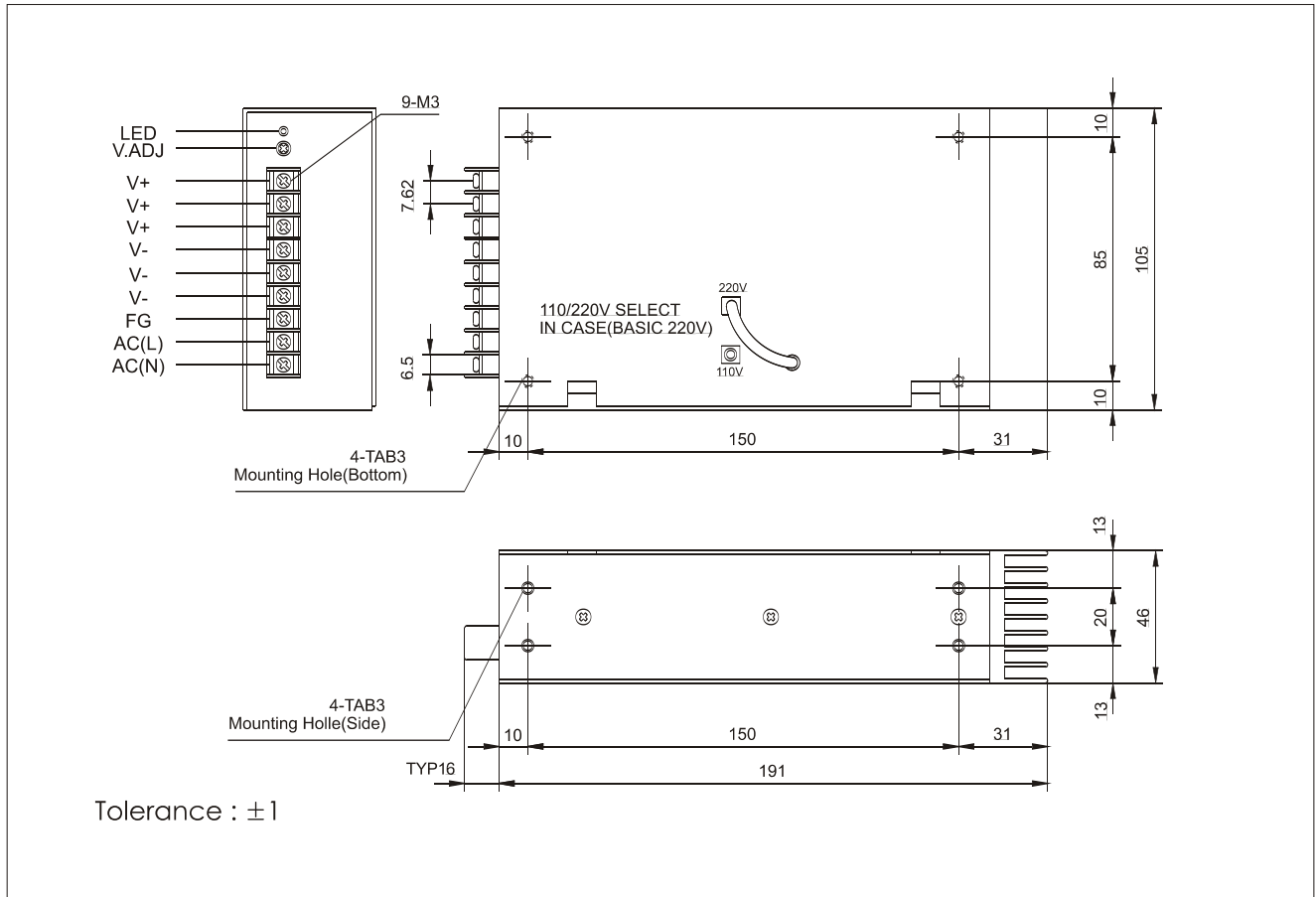

Tolerance : ± 1

Characteristic curve

*(12V MODEL)

A. OVER CURRENT CHARACTERISTICS

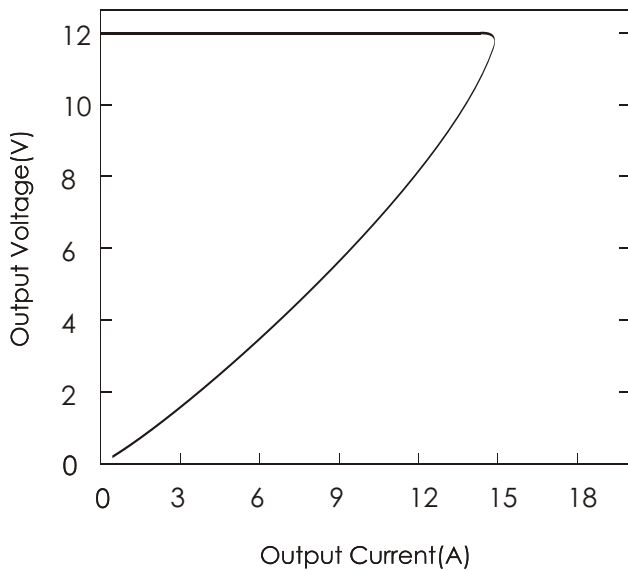

B. DERATING CHARACTERISTICS

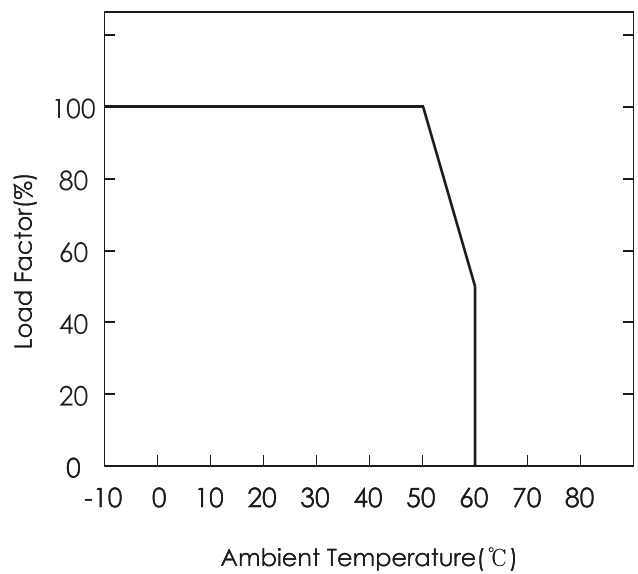

C. EFFICIENCY CHARACTERISTICS

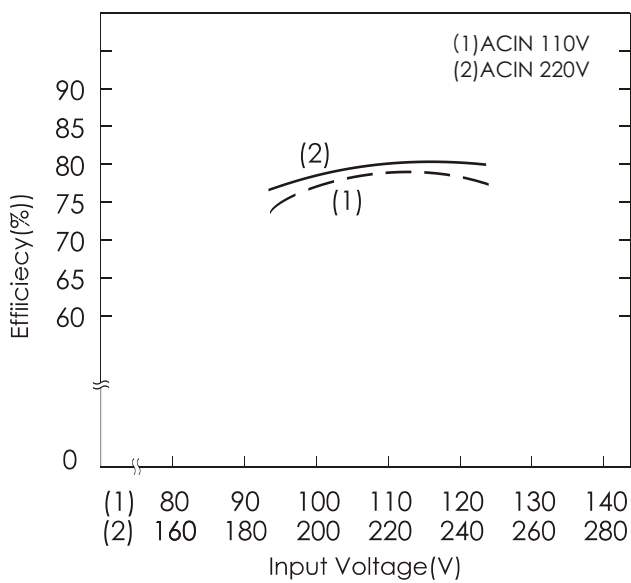

D. RISING/FALLING TIME CHARACTERISTICS

